

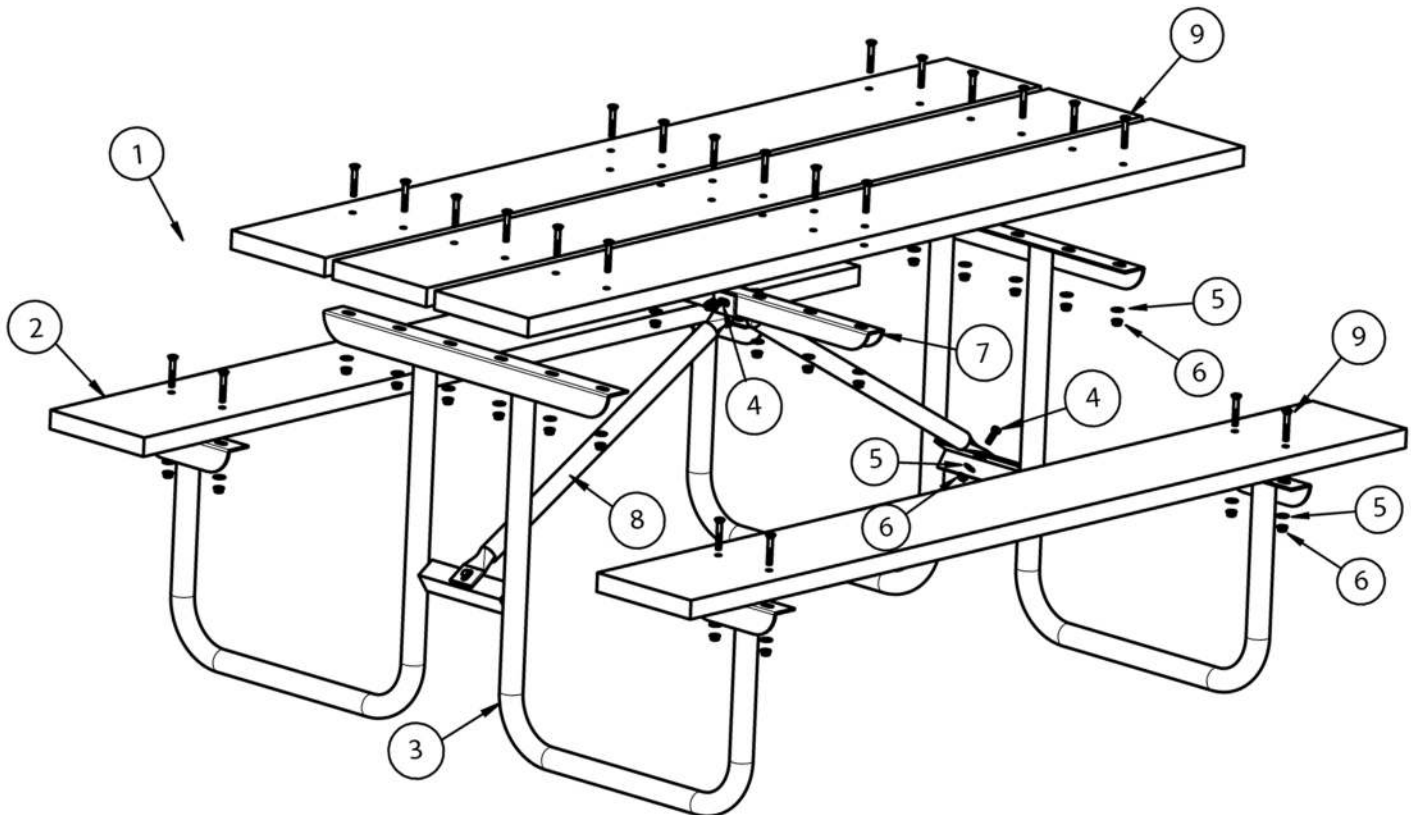

26pcs	4pcs	30pcs	30pcs	2pcs NOT INCLUDED		1pc
				3pcs NOT INCLUDED	2pcs	2pcs

ITEM NO.	DESCRIPTION	QTY
1	2" x 10" Wood Not Supplied	3
2	2" x 10" Wood Not Supplied	2
3	Leg	2
4	5/16" x 1" Hex Head Bolt (Zinc)	4
5	5/16" Zinc Plated Washer	30
6	5/16" Hex Nut (Zinc)	30
7	Center U Channel	1
8	Table brace	2
9	5/16" x 2-1/4" Carriage Bolt (Zinc)	26





Dimensions For Drilling Seat & Table Top Planks

Seat Drill Pattern

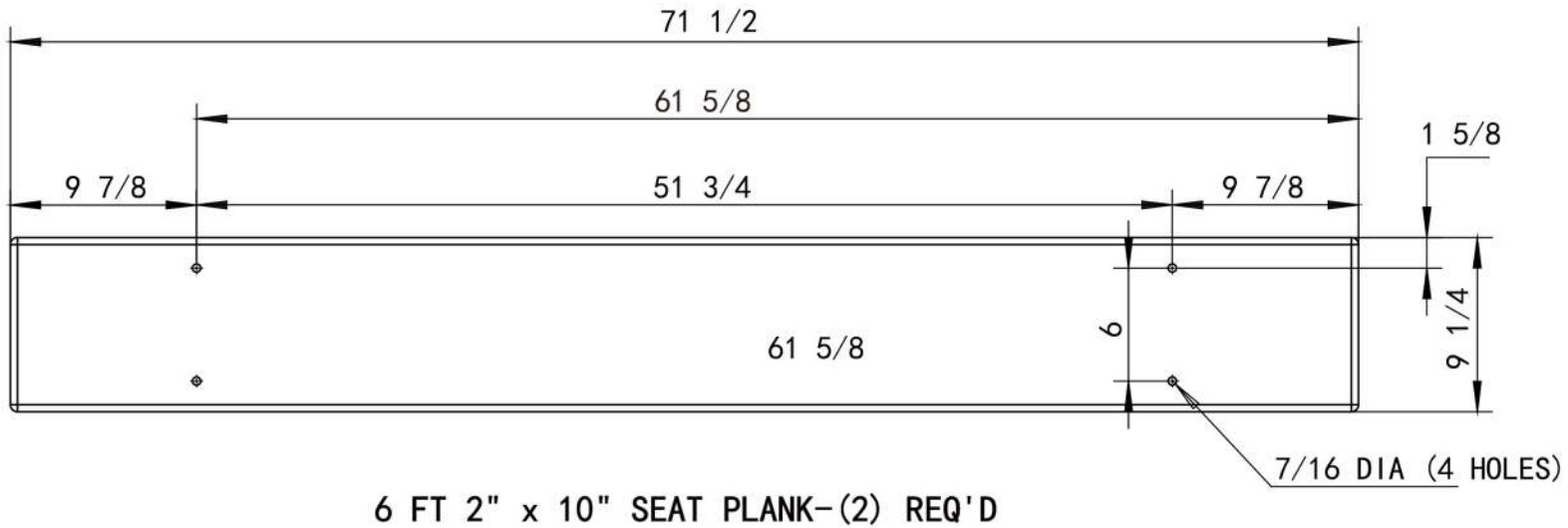

***Dimensions provided are for reference only. Please verify measurements directly with the frame before drilling.**

Table Top Drill Pattern

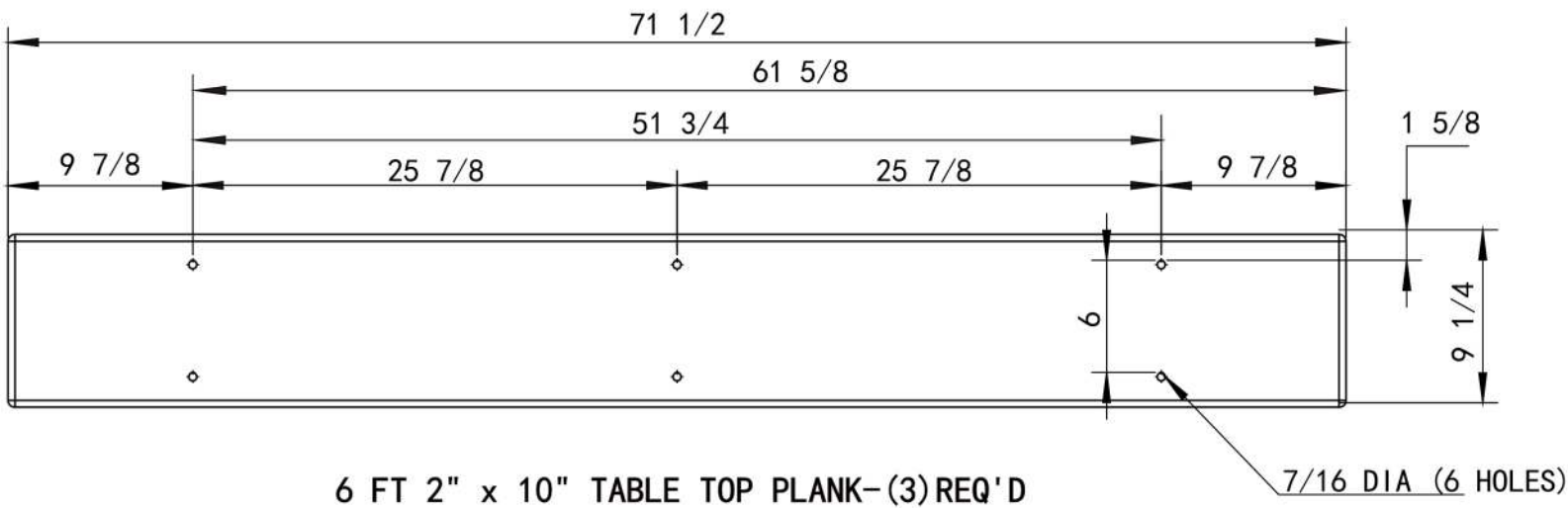

***Dimensions provided are for reference only. Please verify measurements directly with the frame before drilling.**



ITEM NO.	DESCRIPTION	QTY
1	2" x 10" Wood Not Supplied	3
2	2" x 10" Wood Not Supplied	2
3	Leg	2
4	5/16" x 1" Hex Head Bolt (Zinc)	4
5	5/16" Zinc Plated Washer	30
6	5/16" Hex Nut (Zinc)	30
7	Center U Channel	1
8	Table brace	2
9	5/16" x 2-1/4" Carriage Bolt (Zinc)	26

Step 1

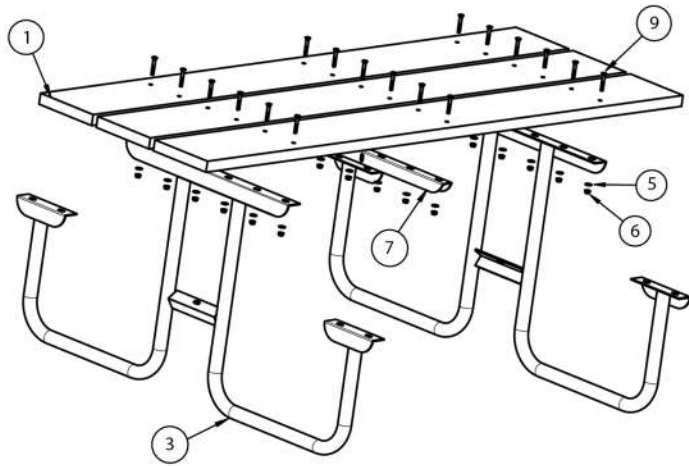

Step 2

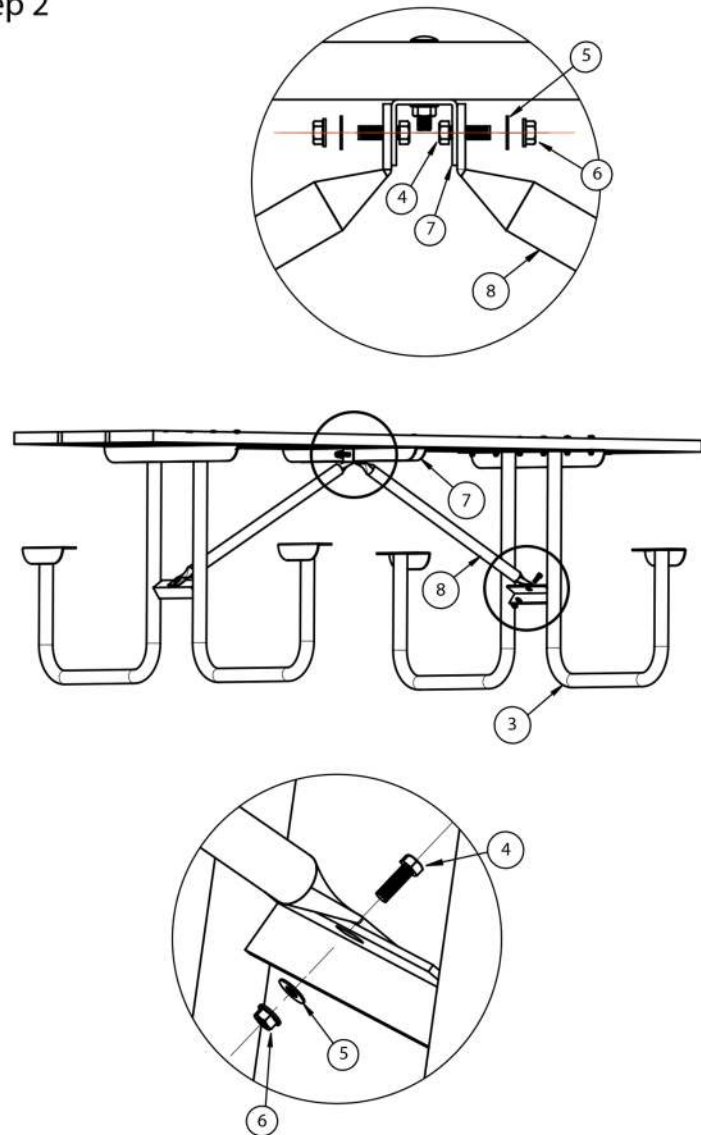

Step 3

